

Project Name:	Fixture Type:
Complete Catalog #:	Date:
Comments:	

# ATLAS SCORPIUS SPORTS LIGHT

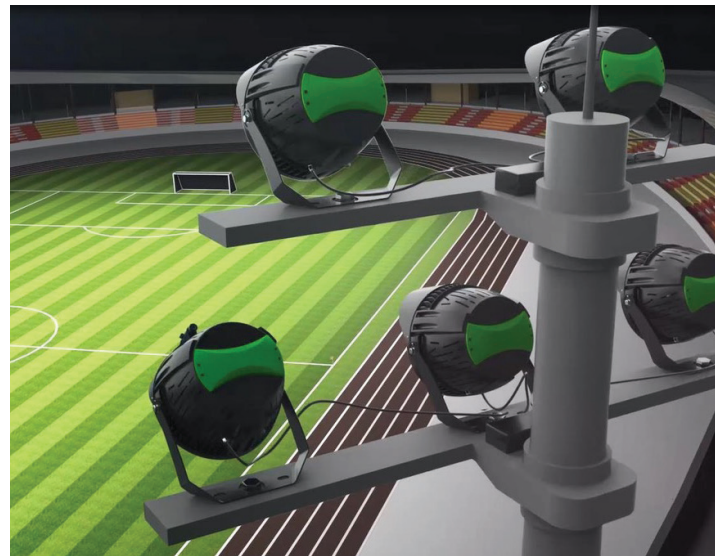

The **Atlas Scorpius Sports Light** combines a modern design with premium performance. Patented thermal management improves the luminaire’s performance, safety, and lifetime. With TLCI >90, the luminaire is broadcast-ready for >1000fps, HD | 4K | 8K, and enables TV broadcasters to film super-slow-motion replays, with a flicker factor <2%. Additional premium features include: IK10 impact rating, IP66 rating, 3G vibration rating, and a 10 kV surge protection device standard.

## FEATURES

- Chipset: OSRAM or Lumileds
- Driver: Inventronics or Philips
- Efficacy up to 160 lpW
- Up to 1200W and 156,000 lumens
- 100-277VAC or 200-480VAC options
- IK10, IP66, 3G vibration rated, salt spray tested
- TLCI >90 for HD broadcasts, Flicker factor <2%

## APPLICATIONS

- Football stadium
- Soccer stadium
- Tennis courts
- Basketball courts
- Golf courses
- Ski slopes
- Industrial areas
- Truck stops
- Toll plazas
- Airports
- Ports



## ORDERING INFORMATION

PART NUMBER	WATTAGE	LUMENS @ 70+ CRI	VOLTAGE	CRI	CCT	MIN ORDER QTY	US STOCK
ECO-OKIA-ASP03-300W-10V-SL1 SCORPIUS	300W	45,000	100-277VAC	70+ or 80+	4000K/5000K/5700K	1	YES
ECO-OKIA-ASP03-300W-20V-SL1 SCORPIUS	300W	45,000	200-480VAC	70+ or 80+	4000K/5000K/5700K	1	YES
ECO-OKIA-ASP03-400W-10V-SL1 SCORPIUS	400W	60,000	100-277VAC	70+ or 80+	4000K/5000K/5700K	1	YES
ECO-OKIA-ASP03-400W-20V-SL1 SCORPIUS	400W	60,000	200-480VAC	70+ or 80+	4000K/5000K/5700K	1	YES
ECO-OKIA-ASP03-500W-10V-SL1 SCORPIUS	500W	75,000	100-277VAC	70+ or 80+	4000K/5000K/5700K	1	YES
ECO-OKIA-ASP03-500W-20V-SL1 SCORPIUS	500W	75,000	200-480VAC	70+ or 80+	4000K/5000K/5700K	1	YES
ECO-OKIA-ASP03-600W-10V-SL1 SCORPIUS	600W	90,000	100-277VAC	70+ or 80+	4000K/5000K/5700K	1	YES
ECO-OKIA-ASP03-600W-20V-SL1 SCORPIUS	600W	90,000	200-480VAC	70+ or 80+	4000K/5000K/5700K	1	YES
ECO-OKIA-ASP03-750W-10V-SL1 SCORPIUS	750W	101,000	100-277VAC	70+ or 80+	4000K/5000K/5700K	1	YES
ECO-OKIA-ASP03-750W-20V-SL1 SCORPIUS	750W	101,000	200-480VAC	70+ or 80+	4000K/5000K/5700K	1	YES
ECO-OKIA-ASP03-1000W-10V-SL1 SCORPIUS	1000W	135,000	100-277VAC	70+ or 80+	4000K/5000K/5700K	1	YES
ECO-OKIA-ASP03-1000W-20V-SL1 SCORPIUS	1000W	135,000	200-480VAC	70+ or 80+	4000K/5000K/5700K	1	YES
ECO-OKIA-ASP03-1200W-10V-SL1 SCORPIUS	1200W	156,000	100-277VAC	70+ or 80+	4000K/5000K/5700K	1	YES
ECO-OKIA-ASP03-1200W-20V-SL1 SCORPIUS	1200W	156,000	200-480VAC	70+ or 80+	4000K/5000K/5700K	1	YES

## TECHNICAL SPECIFICATIONS

LED Type	Osram or Lumileds	Salt Spray	Salt Spray Tested
Driver Type	Inventronics or Philips	Housing Material	Die cast aluminum
Optical Distributions	10°/15°/20°/40°/60°/80°	Finish Material	UV stabilized polyester powder paint
CRI	70+/80+	Rated Life (L70)	>50,000 Hours
Efficacy	Up to 160 Lm/W	Warranty	10 Years, 50,000 Hours Non-Prorated
IP Rating	IP66 Rated	Operating Temperature	-22° - 122°F
Input Voltage	100-277VAC or 200-480VAC	Luminaire Net Weight	300W/400W/500W/600W: 33.1 lbs. 750W/1000W/1200W: 50.7 lbs.
Power Frequency	50-60 Hz	Optic Material	PC (Anti UV & Dust)
Power Efficiency	93%	Optic Cover (Optional)	Tempered glass, 3.2mm, clear, shatterproof, IK08
Power Factor	>0.9 at Max Load	Input Surge Protection	10kV / 20kV
THD	<15%	EPA	300W/400W/500W/600W: 1.27 ft2 750W/1000W/1200W: 2.1 ft2
Flicker Factor	<2%	Controls	0-10V/PWM/Bluetooth/DALI/DMX
Certifications	cULus, FCC		
Impact Rating	IK10		
Vibration	3G Rating		

\*Data is based upon tests performed in a controlled environment and representative performance.

Actual performance can vary depending on operating conditions.

Specifications are subject to change without notice. All specifications are nominal unless otherwise noted.

\*IES files provided on request.

# ATLAS SCORPIUS SPORTS LIGHT

## CONTROLS

Control Options: 0-10V / PWM / Bluetooth / DALI / WIFI / Zigbee / DMX

Scalable control solution enables customization with real-time overrides. Supports Art-Net, DMX RDM, and DALI protocols.

## ACCESSORIES

Optional: Tempered glass optic cover, 3.2mm, clear, shatterproof, IK08.

Optional: 20kV SPD

## PHOTOMETRICS

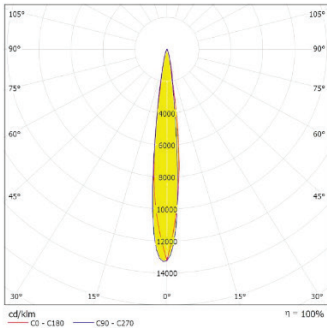

10°

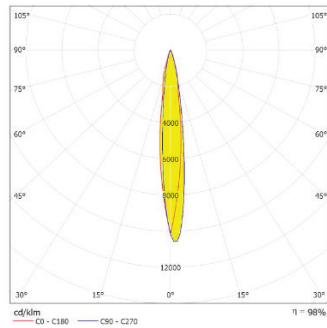

15°

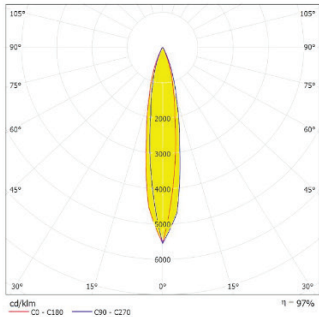

20°

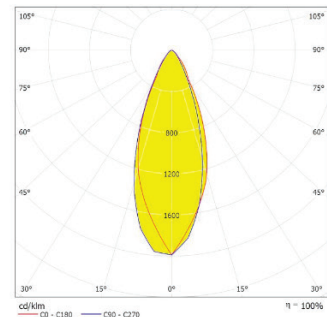

40°

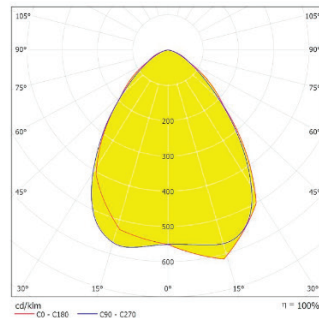

60°

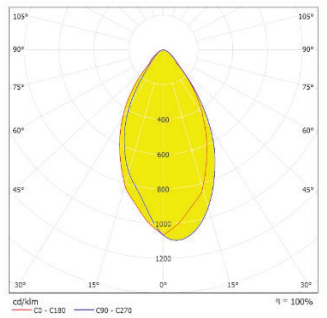

80°

# ATLAS SCORPIUS SPORTS LIGHT

## DIMENSIONS

300W / 400W / 500W / 600W:

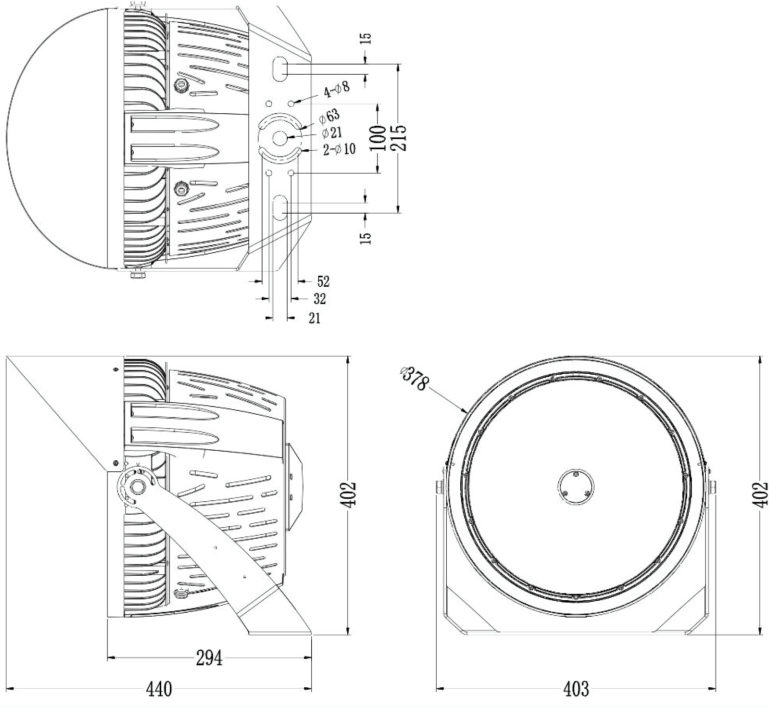

750W / 1000W / 1200W:

