

Project Name:	Fixture Type:
Complete Catalog #:	Date:
Comments:	

# LUNAR DUSK TO DAWN LIGHT



The **Lunar Dusk To Dawn Light™** combines exceptional performance, zero maintenance, simple installation, and great value for dusk to dawn areas. The modern design can be mounted on poles, walls or junction boxes. The Lunar fixture utilizes a prismatic lens that replicates form and performance of 150W high pressure sodium or 175W metal halide fixtures. With high efficiency of 117 lm/W and 100,000 hour L70 lifetime, these are the perfect replacement fixtures for MH/HPS street lights, barn lights, driveways, & parking areas. A twist-lock photocell is included for more energy savings and ease of use.

## FEATURES

- LED Type - NICHIA
- System Efficiency - up to 117 lm/W
- Up to 5,280 lumens
- Input Voltage - 100-277 or 347-480VAC options
- Rebate Eligible - Yes, DLC Standard Listed, Contact for details
- Warranty - 10 Years or 50,000 Hours Non-Prorated

## APPLICATIONS

- Parking Areas
- Retail
- Office
- Medical
- Rural / Driveway / Barn



## ORDERING INFORMATION

PART NUMBER	WATTAGE	LUMENS	VOLTAGE	DIMENSIONS	CCT	MIN ORDER QTY	US STOCK
ECO-2STL-40W	40W	5600	100-277VAC or 347-480VAC Option	14.8" x 7.7" x 7.7"	3000K, 4000K, 5000K, 5700K	2	YES
ECO-2STL-55W	55 W	7700	100-277VAC or 347-480VAC Option	14.8" x 7.7" x 7.7"	3000K, 4000K, 5000K, 5700K	2	YES

## TECHNICAL SPECIFICATIONS

LED Type	NICHIA
Beam Angle	Type V
CRI	73
Efficacy	up to 140 lm/W
IP Rating	IP67
Power Frequency	50-60 Hz
Power Efficiency	>90%
Power Factor	>0.9
THD	<20%
Certifications	cULus, DLC Standard, FCC, RoHS, CE
Fixture Material	Aluminum
Rated Life (L70)	100,000 hours
Warranty	10 Year or 50,000 Hours Non-Prorated
Operating Temperature	-31 to 131 F
Luminaire Gross Weight	9 lbs
Optional Mounting	Wall Mount or Arm Mount
Housing Color	Bronze, Black, White, Gray

\*Data is based upon tests performed in a controlled environment and representative performance. Actual performance can vary depending on operating conditions. Specifications are subject to change without notice. All specifications are nominal unless otherwise noted.

\*IES files provided on request.

# LUNAR AREA LIGHT

## MOUNTING ACCESSORIES - 24" ROUND ARM INCLUDED

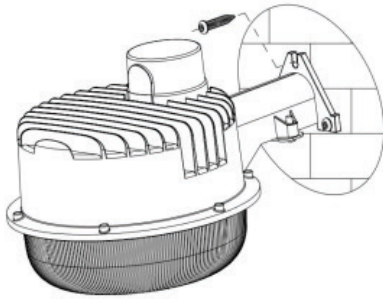

1. Direct Mounting

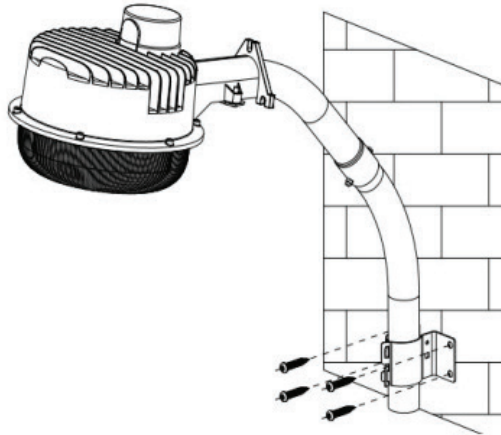

2. ARM MOUNTING

## CONTROLS

Control Options: Twist-Lock Photocell Sensor comes standard. Non-dimming.

## ACCESSORIES

- 24" round arm (included)
- Twist-Lock Photocell Sensor (included)

## DIMENSIONS

