

Project Name:	Fixture Type:
Complete Catalog #:	Date:
Comments:	

## FALCON GARDEN POST TOP LAMP



The **Falcon Garden Post Top Lamp** is an ideal LED replacement for HPS, LPS, MH, MV, and CFL legacy lamps, in post top applications. These lamps have excellent thermal management utilizing die cast aluminum heat sinks, rather than fans. The lamps have high light output, without UV nor IR emissions. They are low EMI, and 100-277VAC input, for ballast by-pass. They have numerous indoor and outdoor applications, including post top, canopy, roadway, and more. The lamps are non-dimmable, up to 140 lumens per Watt, and come with a 5 year, non-prorated warranty.

### FEATURES

- System Efficiency - up to 140 lm/W
- Up to 70,000 lumens
- Input Voltage - 100-277VAC, ballast bypass
- Rebate Eligible - Yes, DLC Listed, Contact for details
- Base - E26 / E27 or E39 / E40 available
- Warranty - 5 years, non-prorated

### APPLICATIONS

- Post tops
- Canopy
- Roadway
- Area Lights



# FALCON GARDEN POST TOP LAMP

## ORDERING INFORMATION

PART NUMBER	WATTAGE	LUMENS	VOLTAGE	BASE	CCT	MIN ORDER QTY	US STOCK
ECO-SN-FLA30W-01C-D	30W	4,350	100-277VAC	Down; E26/E27 or E39/E40	3000K / 4000K / 5000K	12	NO
ECO-SN-FLA30W-01C-U	30W	4,350	100-277VAC	Up; E26/E27 or E39/E40	3000K / 4000K / 5000K	12	NO
ECO-SN-FLA40W-01C-D	40W	5,800	100-277VAC	Down; E26/E27 or E39/E40	3000K / 4000K / 5000K	12	NO
ECO-SN-FLA40W-01C-U	40W	5,800	100-277VAC	Up; E26/E27 or E39/E40	3000K / 4000K / 5000K	12	NO
ECO-SN-FLA50W-01C-D	50W	7,250	100-277VAC	Down; E26/E27 or E39/E40	3000K / 4000K / 5000K	12	NO
ECO-SN-FLA50W-01C-U	50W	7,250	100-277VAC	Up; E26/E27 or E39/E40	3000K / 4000K / 5000K	12	NO
ECO-SN-FLA60W-01C-D	60W	8,700	100-277VAC	Down; E26/E27 or E39/E40	3000K / 4000K / 5000K	12	NO
ECO-SN-FLA60W-01C-U	60W	8,700	100-277VAC	Up; E26/E27 or E39/E40	3000K / 4000K / 5000K	12	NO

## TECHNICAL SPECIFICATIONS

CRI	>80
Efficacy	Up to 140 Lm/W
Environment	Damp Location Listed
Power Frequency	50-60 Hz
Power Efficiency	>87%
Power Factor	>0.9
Certifications	UL, cUL, DLC, FCC
Rated Life (L70)	>35,000 Hours
Warranty	5 Years, Non-Prorated
Operating Temperature	-40° – 113°F
Luminaire Gross Weight	30W: 1.8 lbs / 60W: 1.8 lbs
Base Types	E26/E27 and E39/E40
Dimmable	No

\*Data is based upon tests performed in a controlled environment and representative performance. Actual performance can vary depending on operating conditions. Specifications are subject to change without notice. All specifications are nominal unless otherwise noted.

\*IES files provided on request.

# FALCON GARDEN POST TOP LAMP

## DIMENSIONS

### 30W Base Down:

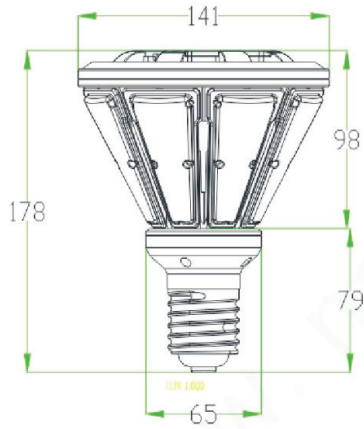

Base	E26/E27	E39/E40
Overall length	166mm	178mm
Diameter	141mm	
N.W	780g	800g

### 30W Base Up:

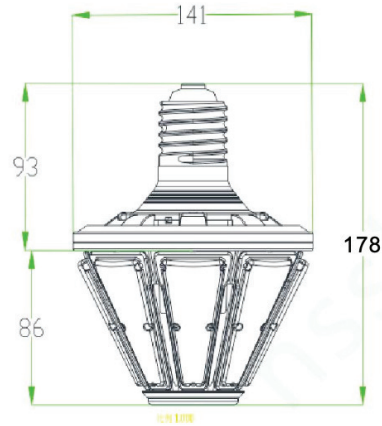

Base	E26/E27	E39/E40
Overall length	166mm	178mm
Diameter	141mm	
N.W	780g	800g

### 40W Base Down:

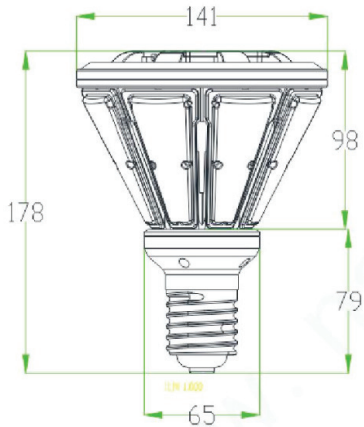

Base	E26/E27	E39/E40
Overall length	166mm	178mm
Diameter	141mm	
N.W	780g	800g

### 40W Base Up:

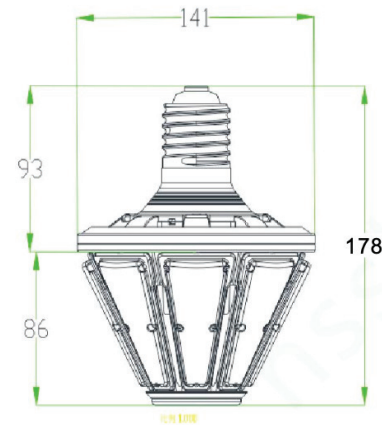

Base	E26/E27	E39/E40
Overall length	166mm	178mm
Diameter	141mm	
N.W	780g	800g

# FALCON GARDEN POST TOP LAMP

## DIMENSIONS

**50W Base Down:**

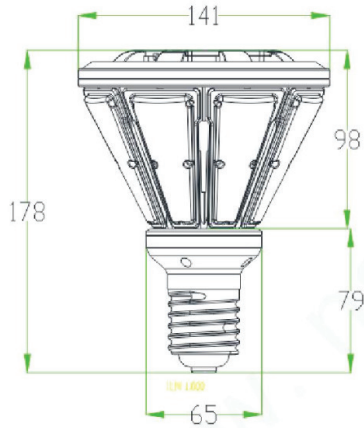

Base	E26/E27	E39/E40
Overall length	166mm	178mm
Diameter	141mm	
N.W	780g	800g

**50W Base Up:**

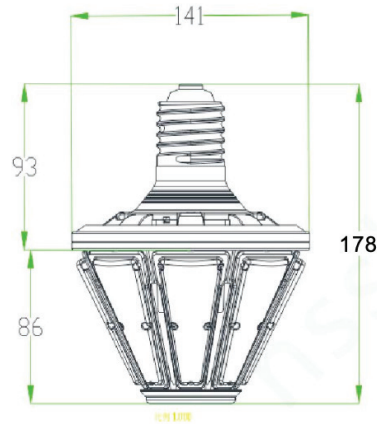

Base	E26/E27	E39/E40
Overall length	166mm	178mm
Diameter	141mm	
N.W	780g	800g

**60W Base Down:**

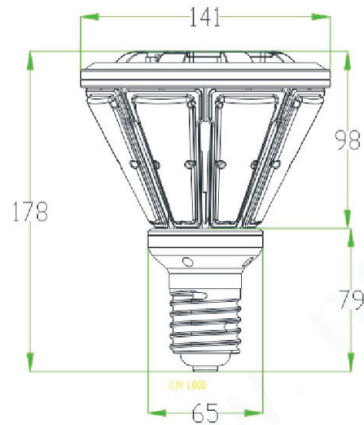

Base	E26/E27	E39/E40
Overall length	166mm	178mm
Diameter	141mm	
N.W	780g	800g

**60W Base Up:**

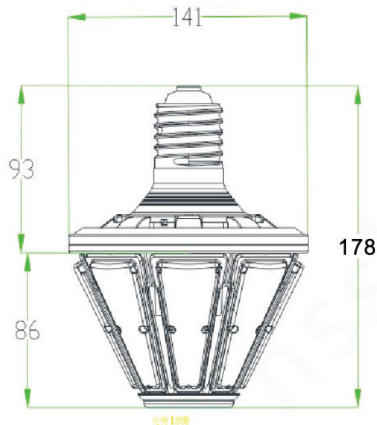

Base	E26/E27	E39/E40
Overall length	166mm	178mm
Diameter	141mm	
N.W	780g	800g