

Project Name:	Fixture Type:
Complete Catalog #:	Date:
Comments:	

# PETRO GEN 2 GAS STATION CANOPY FIXTURE



The **Petro Gen 2 Gas Station Canopy Fixture** has a 1.5", low-profile, simple design. The luminaire is an ideal solution for gas station canopy applications. It includes a high performance driver and chip set, that provides exceptionally high lumens per watt and overall effective light distribution, that is both symmetrical and homogenous. The all-aluminum, die-cast housing guarantees durability, even under the harshest weather conditions. The Petro Gen will perform dependably for more than 10 years or 50,000 hours.

## FEATURES

- System Efficiency - 125 lm/W
- Luminous Flux - up to 18,750 lumens
- Input Voltage - 100-277 VAC
- IP65 rated
- 120 degree beam angle
- Rebate Eligible - Yes, DLC Listed, Contact for details
- Warranty - 10 Years or 50,000 Hours Non-Prorated

## APPLICATIONS

- Gas station canopy
- Car repair canopy
- Parking garage
- Warehouse
- Workshops
- Industrial

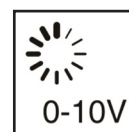

# PETRO GEN 2 GAS STATION CANOPY FIXTURE

## ORDERING INFORMATION

PART NUMBER	WATTS	VOLTAGE	BEAM ANGLE	CRI	LUMENS	LPW	DIMMABLE	MIN ORDER QTY	US STOCK
ECO-CPN-100W-GC	100W	100-277VAC	120°	80+	12000	120 lm/W	0-10V	1	Yes
ECO-CPN-130W-GC	130W	100-277VAC	120°	80+	15,600	120 lm/W	0-10V	1	Yes
ECO-CPN-150W-GC	150W	100-277VAC	120°	80+	18,750	125 lm/W	0-10V	1	Yes

## TECHNICAL SPECIFICATIONS

System Efficacy	125 lm/W
Luminous Flux	up to 18,750 lumens
CCTs	4000K, 4500K, 5000K, 5700K
Beam Angle	120°
CRI	80+
Input Voltage	100-277VAC
Power Frequency	50-60 Hz
Power Efficiency	>90%
Certifications	UL, DLC , FCC
IP Rating	IP65
Lifetime (L70)	50,000 hours
Warranty	10 years or 50,000 hours non-prorated
Operating Temperature	-40°F – +104°F
Housing Color	White
Dimmable	0 –10V
MH / HPS Equivalent	150W LED = 250-300W MH/HPS

\*Data is based upon tests performed in a controlled environment and representative performance. Actual performance can vary depending on operating conditions. Specifications are subject to change without notice. All specifications are nominal unless otherwise noted.

\*IES files provided on request.

# PETRO GEN 2 GAS STATION CANOPY FIXTURE

## INSTALLATION OPTIONS

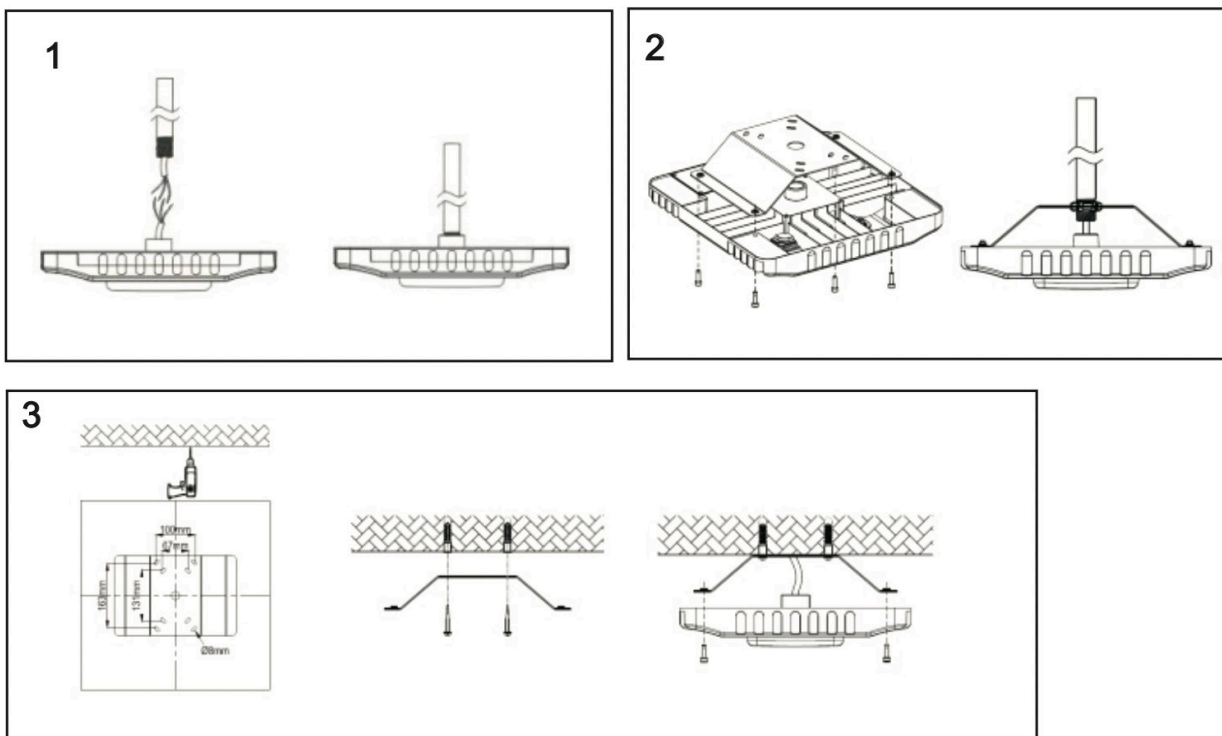

## CONTROLS

Control Options: 0-10V

## PHOTOMETRICS

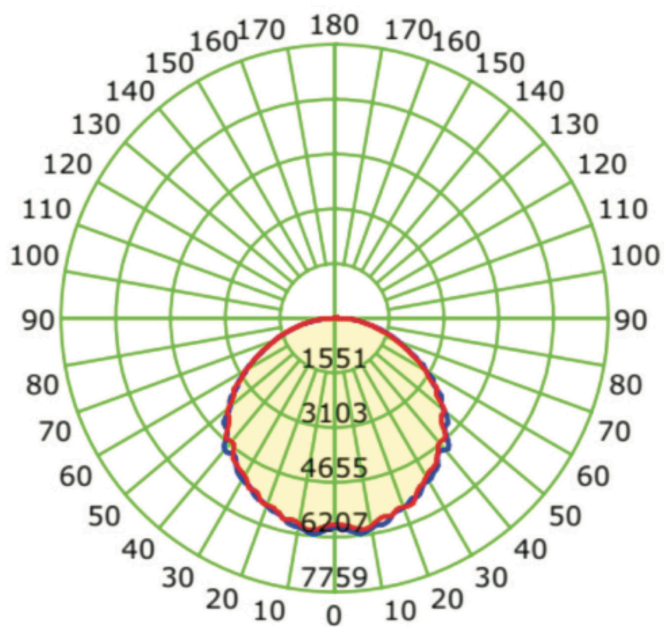

## DIMENSIONS

