

Project Name:	Fixture Type:
Complete Catalog #:	Date:
Comments:	

NIGHT OWL III SELECTABLE LARGE LENS FULL CUT OFF WALL PACK



The **Night Owl III Selectable Large Lens Full Cut Off Wall Pack** delivers premium performance in a sleek, low profile luminaire. It is 3-wattage & 3-CCT selectable, replacing up to nine dedicated wattage & CCT wall pack models. This significantly reduces inventory requirements for distributors and contractors. The fixture is ideal for warehouses, stadiums, manufacturing plants, parking lots, shopping centers, and more. The luminaire is both cULus and DLC Premium listed. The housing is a heavy die-cast aluminum alloy with bronze powder-coat finish, and a glass optic. The backplate is designed for easy wall mounting. There is an optional photocell for automatic dusk-to-dawn operation, as well as 0-10V dimming capability.

FEATURES

- 120W/100W/80W selectable
- 3000K/4000K/5000K selectable
- cULus listed
- DLC Premium
- 120 degree beam angle
- Heavy duty die-cast aluminum housing with glass optic
- Up to 120 watts and 15,600 lumens
- Replaces up to 400W metal halide or HPS
- 0-10V dimmable
- Photocell option

APPLICATIONS

- Warehouses
- Stadiums
- Manufacturing plants
- Parking lots
- Shopping malls
- Supermarkets
- Car dealerships



NIGHT OWL III SELECTABLE LARGE LENS FULL CUT OFF WALL PACK

ORDERING INFORMATION

MODEL #	WATTAGE SELECTABLE	LUMENS @ 5000K	CCT SELECTABLE	INPUT VOLTAGE	MINIMUM ORDER QTY	US STOCK
ECO-2WP-80/100/120W-MCCT	80W 100W 120W	10,400 13,000 15,600	3000K 4000K 5000K	120-277VAC	2	Yes

TECHNICAL SPECIFICATIONS

Input Voltage	120-277VAC
Wattage Selectable	80W / 100W / 120W
Power Frequency	50-60Hz
Power Factor	>0.9
Lumens	Up to 15,600
Beam Angle	120 degrees
CRI	80+
CCT Selectable	3000K / 4000K / 5000K
Efficacy	130 lm/W
Operating Temperature	-4° F to 113° F
Control Options	Wattage selectable, CCT selectable, 0-10V dimming, photocell option
Housing Materials	Die-cast aluminum alloy with glass optic
Rated Life	>50,000 hours
Certifications	cULus wet location, DLC Premium, FCC
Equivalency	Replaces up to 400W MH or HPS
Warranty	10 years or 50,000 hour non-prorated

*Data is based upon tests performed in a controlled environment and representative performance. Actual performance can vary depending on operating conditions. Specifications are subject to change without notice. All specifications are nominal unless otherwise noted.

*IES files provided on request.

NIGHT OWL III SELECTABLE LARGE LENS FULL CUT OFF WALL PACK

CONTROLS

Control Options: Wattage selectable, CCT selectable, 0-10V dimming, photocell option.

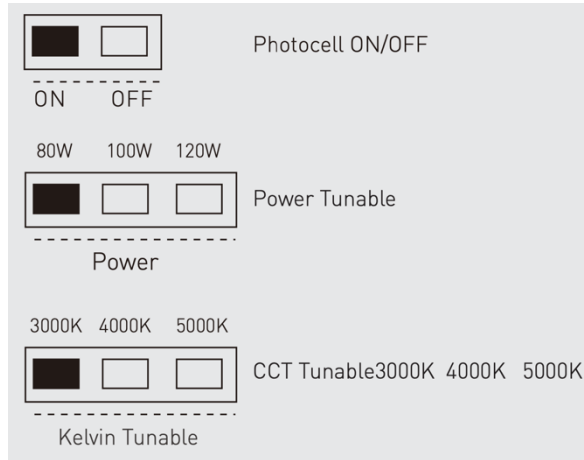

DIMENSIONS unit: mm/inch

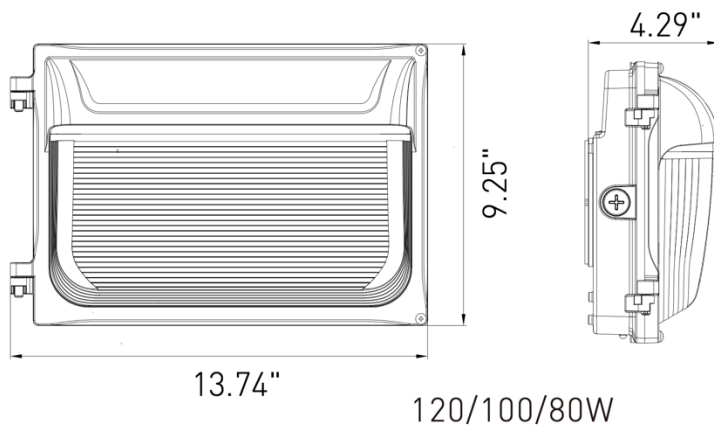

PHOTOMETRICS

LS-4WP120/100/80W

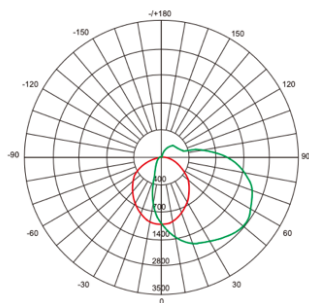

UNIT:CD
 - C0/180,113.7
 - C30/210,100.1
 - C60/240,108.6
 - C90/270,130.9

Lumens:15600LM
 Test Number:120W
 Test Number:5000K

LS-4WP120/100/80W

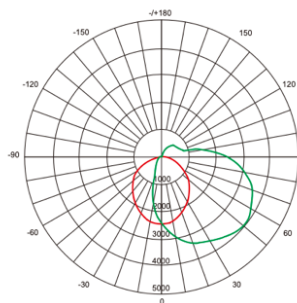

UNIT:CD
 - C0/180,120.1
 - C30/210,120.9
 - C60/240,111.3
 - C90/270,131.4

Lumens:13000LM
 Test Number:100W
 Test Number:5000K

LS-4WP120W/100/80W

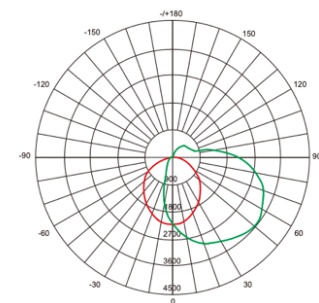

UNIT:CD
 - C0/180,115.4
 - C30/210,121.0
 - C60/240,108.4
 - C90/270,132.1

Lumens:10400LM
 Test Number:80W
 Test Number:5000K

INSTALLATION INSTRUCTIONS

1. Unscrew the larger tooth plug on the side of the lamp, use a Phillips screwdriver.

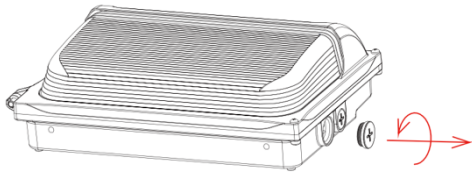

2. Adjust the power, color temperature, and light-sensing switches to the appropriate gear as needed. If the purchased lamps do not have color temperature optional or photocell sensor function, the color temperature optional or photocell sensor gear is empty.

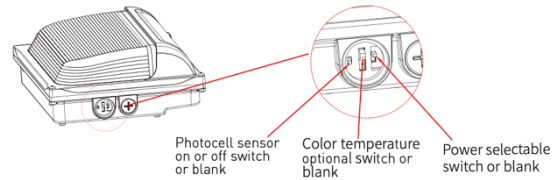

3. Attach the larger tooth plug to the light fixture, use a Phillips screwdriver.

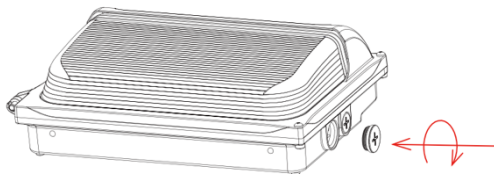

4. Use a screw driver to unscrew the lamp screws and remove the upper half of the fixture.

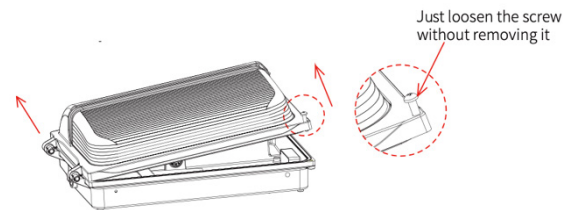

5. Unscrew the cover of the entry hole on the lamp base and remove the cover.

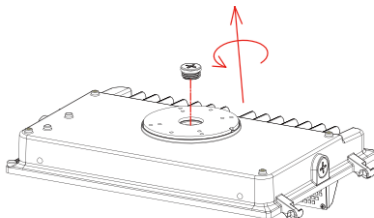

6. According to the embedded terminal box, punch the corresponding mounting hole on the light's mount.

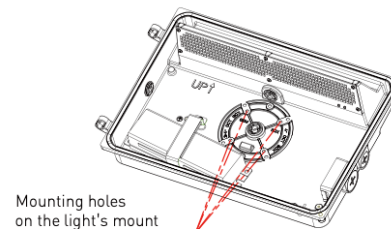

7. Put the input line in the embedded box passes through the waterproof pad and then passed through the lamp base.

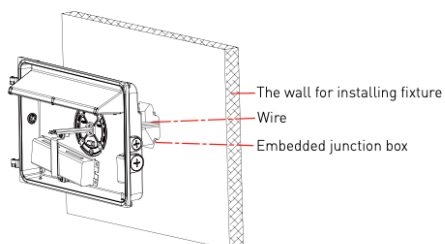

8. Use screw to lock the lamp base on the embedded junction box, And ensure the balance of the horizontal column.

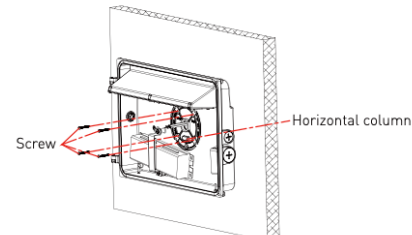

INSTALLATION INSTRUCTIONS

- 9.** Connect the input wire and the dimming wire of the light, then put the connected wires into the embedded terminal box.

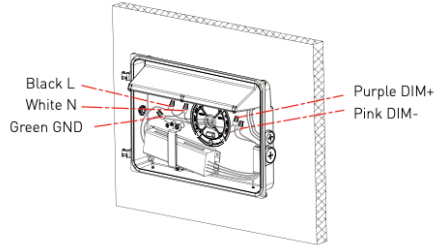

- 10.** Turn the power or color temperature switch to the required position, and pull out the rubber plug at the water leakage hole.

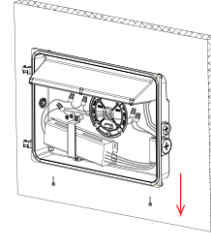

- 11.** Insert the rotating shaft of the upper cover into the rotating shaft hole of the bottom shell.

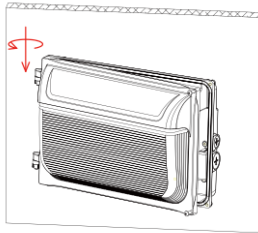

- 12.** Lock the upper cover screws into the bottom shell with a cross screwdriver.

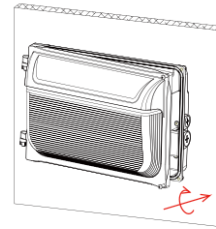

- 13.** Fill the gap between the lamp and the wall with silicone sealant to prevent rainwater from entering the junction box.

